

# AIR TEMPERATURE SENSORS

for direct immersion

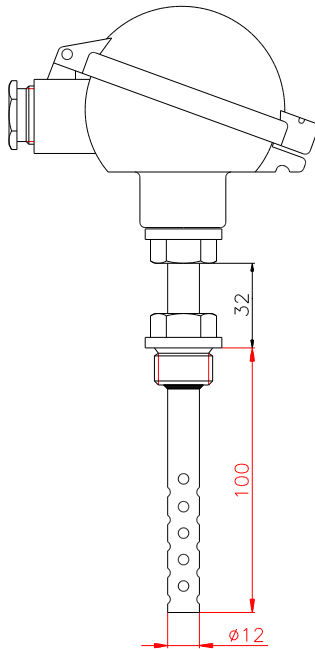

## Specifications:

Type	:	resistance thermometer with fixed mounting
Temperature range	:	-30 to +70 °C
Element type	:	Pt100, single
Resistance values and tolerances	:	IEC-751 class B (1/3 DIN at 0 °C)
Wiring system	:	3-wire
Connection head	:	cast aluminium with swing cover
Protection tube	:	round 12 mm stainless steel, perforated with open end
Mounting thread	:	1/2" BSP.P
Cable entry	:	PG 16 cable gland
Approval	:	Bureau Veritas

## Ordering code

OTP-18037- Pt100

## Specifications:

Type	:	resistance thermometer with adjustable mounting bush
Temperature range	:	-30 to +70 °C
Element type	:	Pt100, single
Resistance values and tolerances	:	IEC-751 class B (1/6 DIN at 0 °C)
Wiring system	:	4-wire
Lead wire	:	PVC insulated flexible wire
Lead wire length 'B'	:	to be specified; replace box in ordering code with required length; our standard length is 3000 mm
Protection tube	:	round 12 mm stainless steel, perforated with open end
Mounting thread	:	1/2" BSP.P
Max. immersion length	:	150 mm
Probe length	:	200 mm
Approval	:	Bureau Veritas

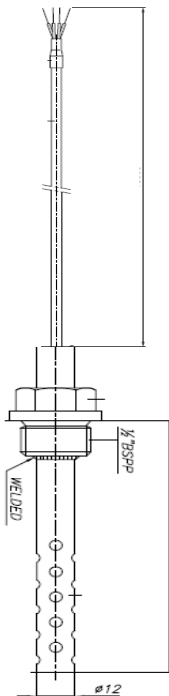

## Ordering code

OTP-18015-Pt100- □ mm